

WEEK 1: CEM3340 (Simplified) Complex Voltage Controlled Oscillator

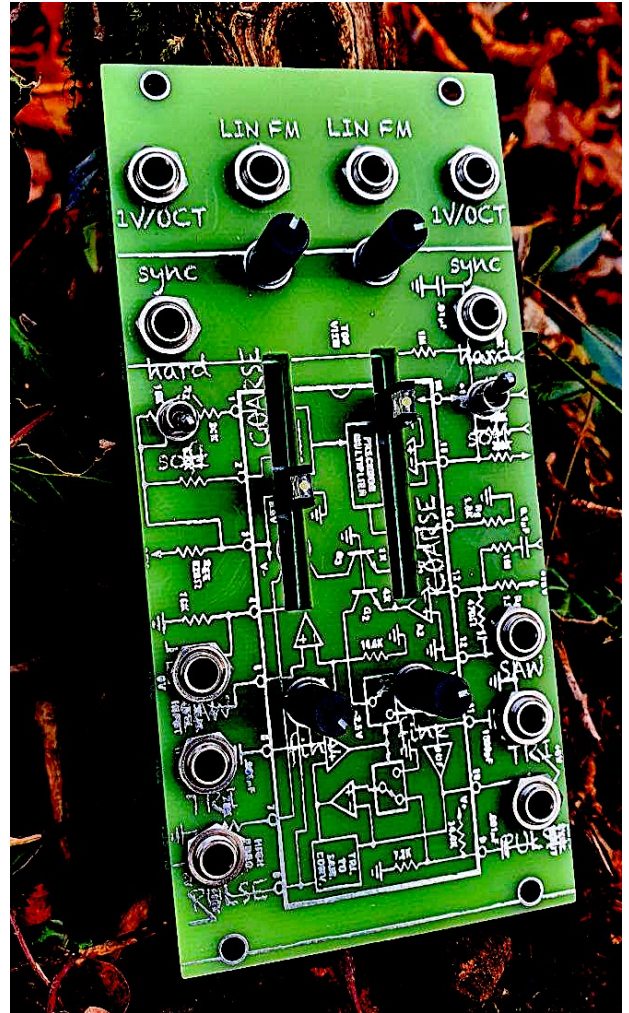
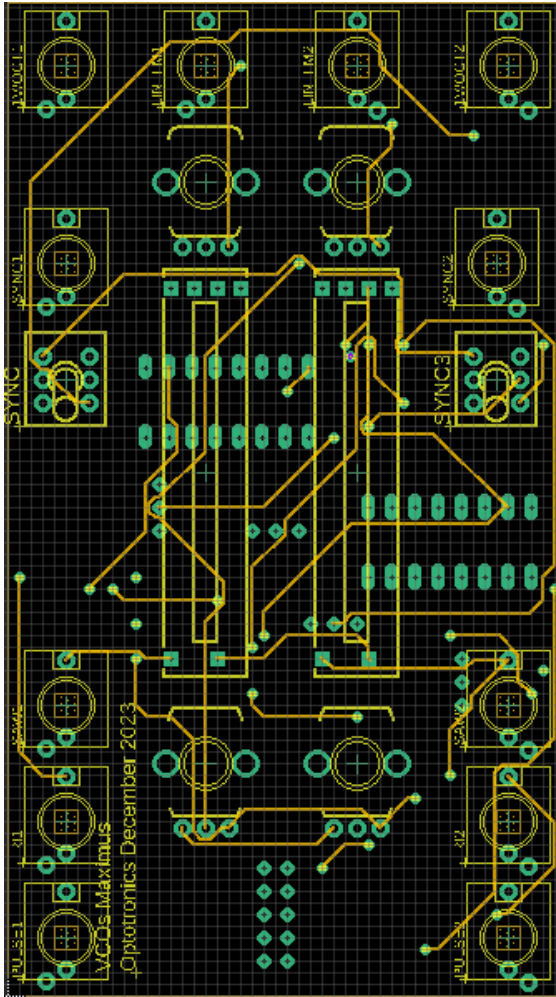

What a Difference a Chip Makes...

In electronic musical instruments and high performance audio equipment nationwide and around the world—the Curtis Electromusic IC “chips” make a very practical difference.

Our line of consistent Performers.

3310: Our voltage controlled envelope generator with unequalled tracking and CV rejection.

3320: VC. 4-pole filter, complete with VC resonance, connects into any filter type.

3330: Dual VCA with exponential and linear control. Class A to Class B operation. Lower noise, distortion and CV feed-through than ever!

3340: A totally self-contained exponential-linear VCO with Full temperature compensa-

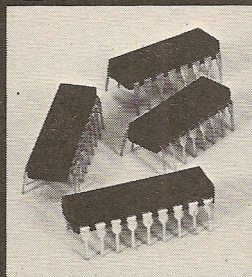

tion—no more Q81's (on chip summer, and 3 output waveforms).

Custom IC design made practical.

Count on us for innovative design approaches to your application specs. And we stay with your IC in production and in interface with your product. That's how Curtis makes Custom really cost-effective.

Performance, prompt delivery, and savings!

Pin-for-pin, dollar-for-dollar, custom or off-the-shelf, we offer the package that adds up to unmatched quality. For a complete description of what a difference our chips make, call or write today!



CURTIS ELECTROMUSIC SPECIALTIES

2900 Mauricia Ave. • Santa Clara, CA 95051 • (408) 247-8046



What is an oscillator?

An oscillator consists of an electronic circuit, which produces repetitive, periodic signal. This signal usually jumps between two states (oscillates). Think about pendulum, or a ball jumping up and down. Oscillator behaves quite similarly.

Electronic oscillator needs few important components:

1) resistor $\sim\sim\sim$ (or 'variable resistor' - potentiometer (cool people call it 'pot' - and no, it doesn't refer to a cooking pot, or cannabis))

2) capacitor $\parallel\parallel$ ('cap' - I won't repeat the previous joke)

3) some kind of semiconductor - an op-amp (operational amplifier), transistor pair or.. CEM3340!).

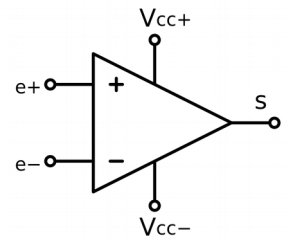

How does it oscillate? (a bit of theoryyyyyy)

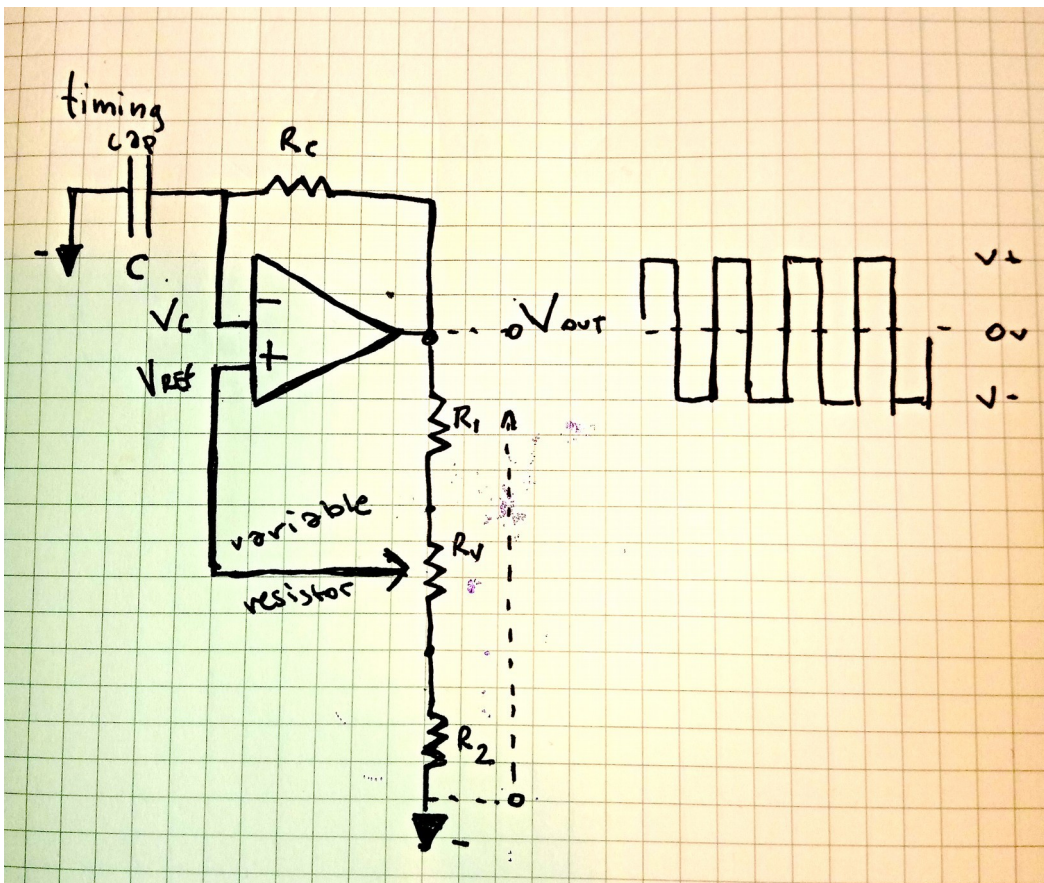

The energy (V) is exchanged between the active and the passive components and the frequency of oscillations is determined by the charging and discharging time-constants involved in the process. (time-constant stands for the time required to charge the capacitor via resistor)

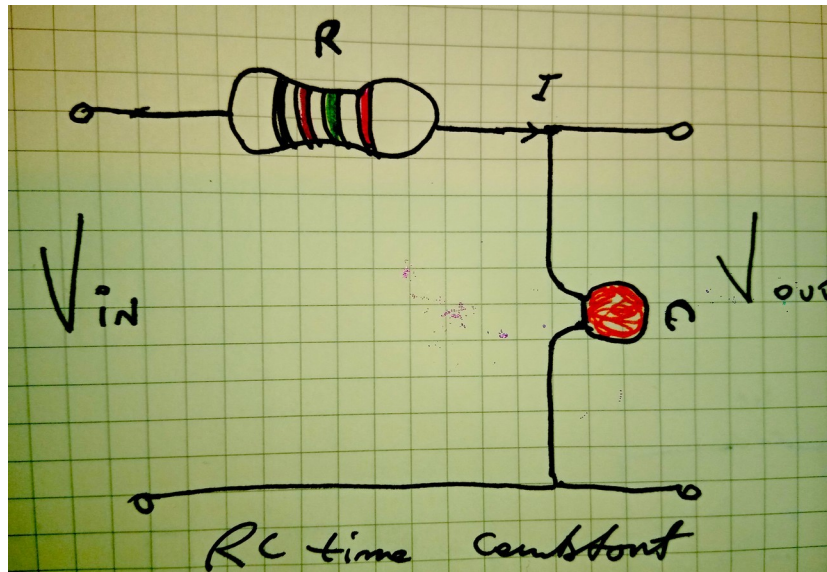

Practically, the oscillators are nothing but the amplifier circuits which are provided with a positive feedback wherein a part of the output signal is fed back to the input.

In the op-amp circuit the op-amp works as an analogue comparator. An op-amp comparator compares the voltages on its two inputs and gives a positive or negative output depending on whether the input is greater or less than some reference value, V_{REF} .

The capacitor, C (timing cap) starts to charge up from the output voltage, V_{out} through resistor, R at a rate determined by their RC time constant. Which basically is the value of C and R . The smaller value of C , the quicker it takes for C to be charged (filled with energy); the same with the resistor - the smaller value, the less resistance, the faster the energy passes through. And yes, as you can guess, the faster the C is charging (via R) the higher the frequency of the oscillator! (check out my professional drawing):

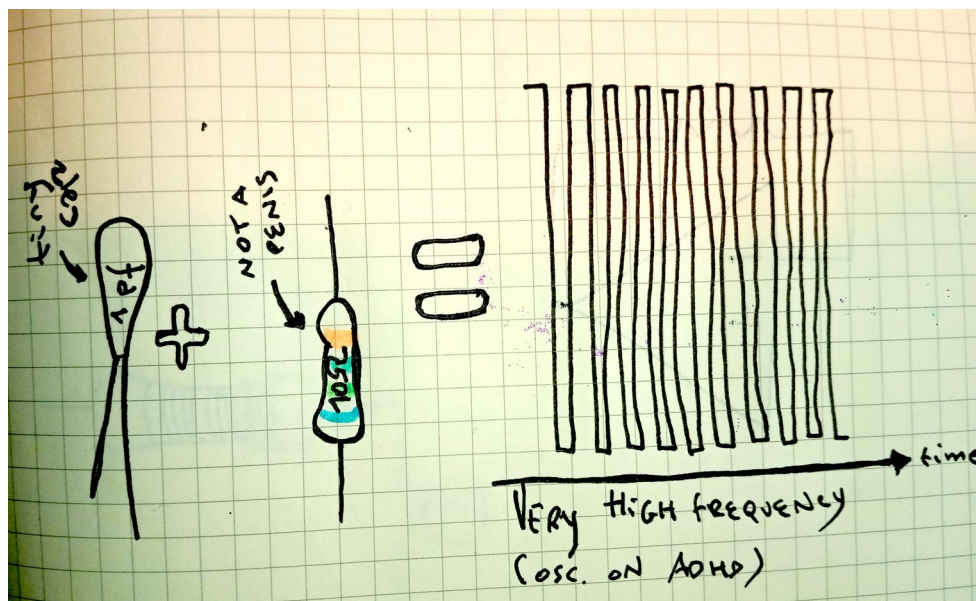
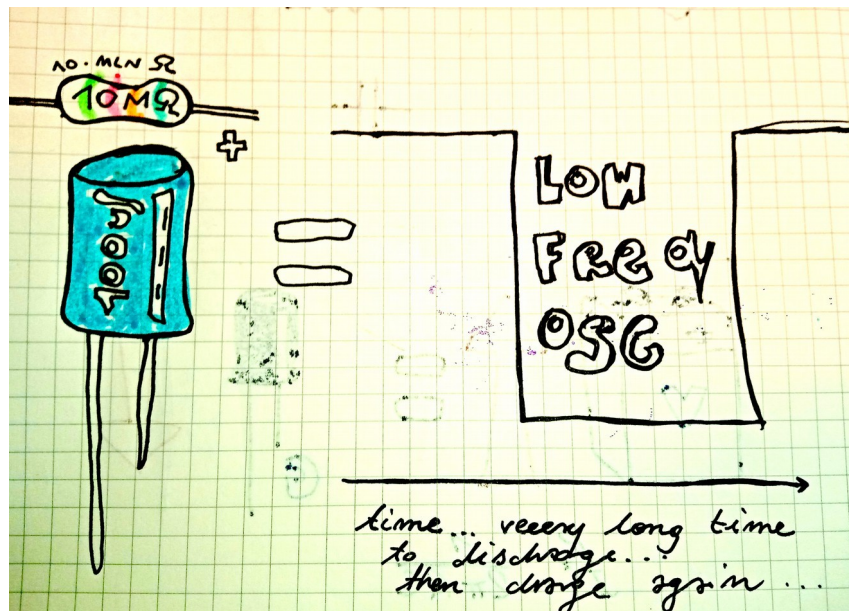

As soon as the capacitors charging voltage at the op-amps inverting (-) terminal is equal to or greater than the voltage at the non-inverting terminal (+) (the op-amps output voltage fraction divided between resistors R_1 and R_2), the output will change state and be driven to the opposing negative supply rail.

But the capacitor, which has been happily charging towards the positive supply rail ($+V(\text{sat})$), now sees a negative voltage, $-V_{\text{across}}$ across its plates. This sudden reversal of the output voltage causes the capacitor to discharge toward the new value of V_{out} at a rate dictated again by their RC time constant.¹ This repeats for everrrrrrr and everrrrrrr.

¹ This is from electronic-tutorials, check the sources.

But, what about our potentiometer (RV)? As you might have guessed, it would be NICE if we can change the frequency of an oscillator. By adjusting RV we can control the amount of resistance.

Ok, back to basics.. Let's talk about various waveforms.

In synthesisers, there are few kinds of oscillators: sine, triangle, ramp (up&down), saw, square, pulse. Shapes of those waveforms are formed by it's harmonic content. So..

SINE WAVE - consists of ONLY fundamental harmonic. The sine wave is the most fundamental of all waveforms because all other sounds are composed of sine waves that occur simultaneously at multiple frequencies. Flute-like sound. It's also an awesome wave for synthesising kickdrums!

Daphne Oram's take on sine wave:

The sine wave is a fascinating phenomenon. The strange fact is that if you take the graph of one, and cut off part of it, you don't reduce it, you add more sine waves to it!



is just one fundamental wave at one pitch, but if we

cut off the start  (the dotted portion), leaving ourselves

with  we find it gives us a sound which is much richer, for

it has lots of overtones sounding above the fundamental note. Many frequencies (or pitches) are sounding together—a really complex recipe this one, resulting in a sort of 'chord' which gives a strident timbre (a richer tone quality), far more striking to the ear than the inoffensive, pallid sine wave.

Chopping any bits off a sine wave always results in additional sine waves being added. If we lop off these bits  we again

arrive at a very rich sound  which mathematically we

find to be (roughly speaking) the fundamental pitch (e.g. 100 Hertz), plus 100 Hz multiplied by 3, 5, 7, 9, 11, 13 etc. In other words, by 'squaring' off the sine wave we have added to it its uneven harmonics. Here's an Alice-through-the-Looking-Glass-cum-Montaigne sort of world—you take something away only to make the loser richer!

TRIANGLE WAVE - consists of only odd harmonics. Much quieter than saw or square wave.

SAWTOOTH WAVE - consists of both odd and even harmonics and creates loud, brassy sound. Add 4 of them with an octave apart (and some chorus effect) and you have 'hoover sound' (and you're ready to make some hardcore) Add 7 of them and you have a 'supersaw' (and you're ready to make trance !)

SQUARE WAVE & PULSE(rectangle) - both waves oscillate only between two states - usually + and - 5V. Pulse is shorter than square wave (positive portion of the cycle is not equal negative portion). So if you have equal positive and negative portions of the cycle, you have a square wave (square - all sides equal). At low frequencies you can use them as a trigger. Loud and harsh in audio ranges. 50...

PWM - pulse with modulation (you also need that to create the hardcore 'hoover' effect) - variable % duty cycle of the pulse wave. 50% duty cycle = square wave; any other variation = pulse wave.

Daphne Oram's recipe for square wave:

Just now, when we cut off the 'top' and 'bottom' of the sine wave curve  we distorted the wave shape so much that

we, almost, arrived at this shape . This wavepattern we

call a square wave and Jean Fourier tells us that it consists of the fundamental and its uneven harmonics (as we have already noted); but he also says that these uneven harmonics have a pleasing symmetry in their amplitude proportions (the proportions governing the volume we hear). It's like this . . . the 3rd harmonic, which is three times the frequency of the fundamental, has $\frac{1}{3}$ of the amplitude of the fundamental, the 5th harmonic $\frac{1}{5}$ of the amplitude of the fundamental, the 7th $\frac{1}{7}$. . . and so on.

So a graphic 'cookery recipe' for making a square wave would look like this.

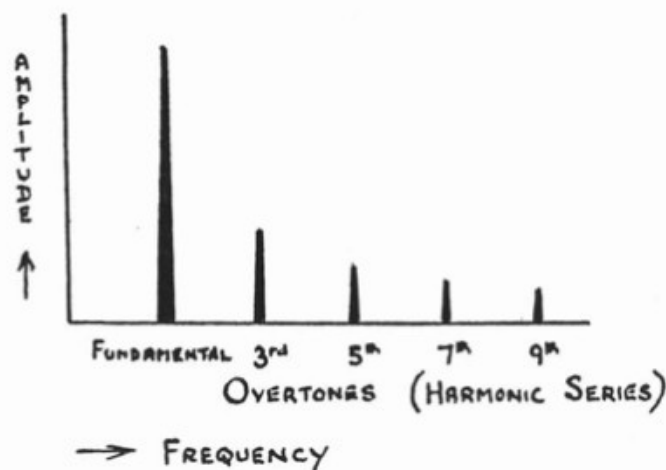
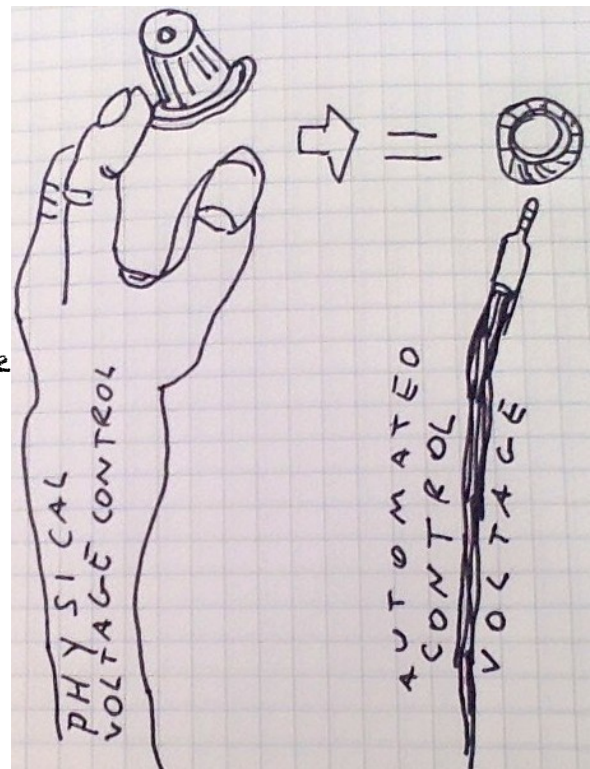

Fig. 6(a). Square wave 'recipe'.

What is Control Voltage?

In the eurorack world CV is widely used for automating patches - which basically means replacing knobs with continuous, yet changing voltage (usually ranging between +/-5V). (sorry for overly sexual drawing). In the case of V(oltage)C(ontrolled)O(scillator) CV input is controlling the frequency (pitch) of the oscillator. But wait, there are few CV inputs here.... Ill get back to it in a bit. But first...



What's the deal with temperature vs. frequency vs. voltage vs. capacitors?

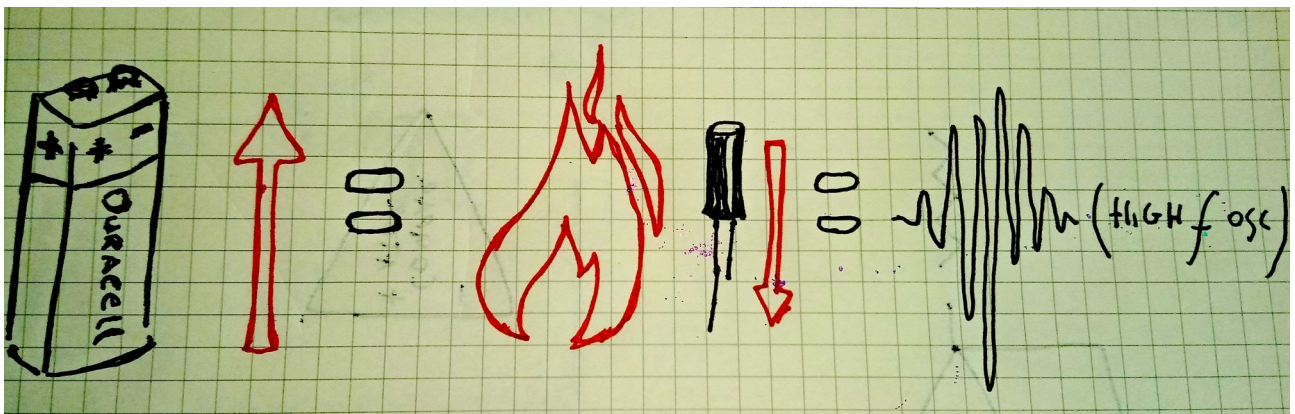

There's a fancy equation :

$$f = 1/2\pi RC$$

Can you spot RC time constant? Also Pi! [cool]

So this apparently means, that (as we discussed before), the smaller the value of the capacitor, the higher the frequency of the oscillator. Which leads, as to Voltage Controlled Oscillators! Since

we want to control the f by applying V , we are increasing the frequency and as the input voltage or control voltage increases, the capacitance gets reduced. Hence, the control voltage and frequency of oscillations are directly proportional. WOOOAHHHHHHHH

There's a small issue tho. THIS PRODUCES HEAT. Voltage = Heat = problems. This has been a massive challenge for designers as oscillators become SUPER UNSTABLE. But since we are using our fancy CEM3340, which has all the fancy temperature-compensation circuitry we don't give a damn about that!!! bloody thermodynamics. (or as hippy would say "everything is a flow of energyyyyyy maaaaaannnnnn")

What's the deal with exponential 1V/OCTAVE tracking ?

For every 1V increase on the input, the output frequency will go up by one octave. Since Bob Moog was well into keyboards (Buchla on the other hand, preferred touch-sensitive points, which is definitely more edgy), which he wanted to implement in synthesisers, he came up with a circuit, which take a linear voltage in and produce an exponential voltage which is fed into the VCO (since we humans hear things on exponential scale).

"As a concrete example, imagine you're playing a concert "A" at 440 Hz. You can play an octave up by playing 880 Hz, or an octave down by playing 220 Hz. A fifth up is an "E" at $440 * 3/2 = 660$ Hz. The third comes in a $440 * 5/4 = 550$ Hz. All this is to say that musical intervals are all about ratios of frequencies (source: hackaday)

exponential converter circuit:

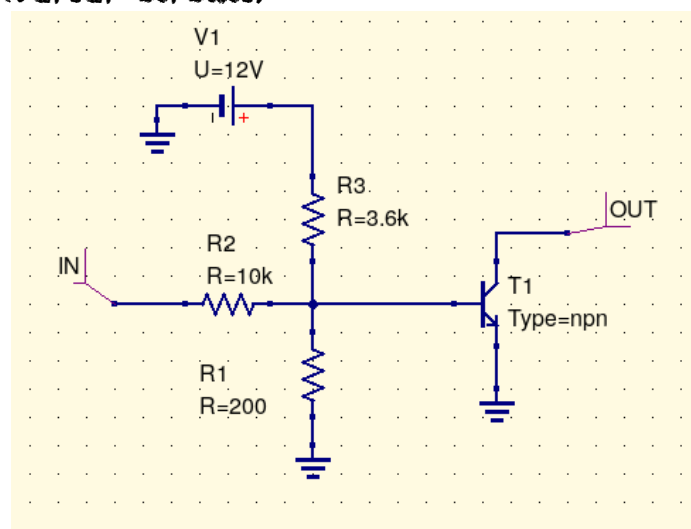

Luckily, we don't need to worry about this in our circuit, because it's super easy to make this work with CEM3340 (also those chips are bloody expensive). Anyway, this is the circuit (for more info check out Thomas Henry article listed below).

What is Complex VCO (brief history)?

The concept of Complex VCO comes from Don Buchla, who cultivated additive synthesis (together with Serge) or, West Coast synthesis style (Moog=East Coast, subtractive synthesis).

[So you have two different ways of waveshaping - you either subtract - reduce harmonic content by filtering your sound source, or you add harmonic content by modulate your wave with another one. It's a bit like colour mixing:

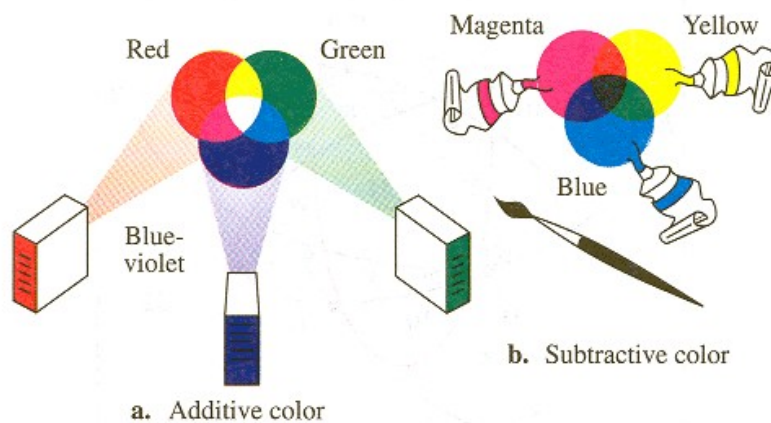

where colour pigments are representing harmonic contents of the sound source.]

To make things short, Complex VCO stands for two VCOs in one module - master/principal and slave/modulator oscillator.

Modulator oscillator is used for ... yes, you guessed! Frequency and amplitude modulation of the master oscillator. This is Buchla's complex waveform generator model 259:

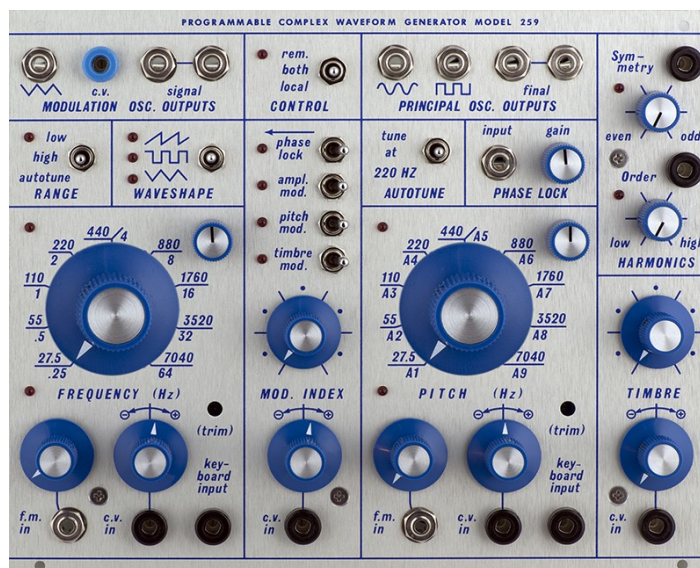

output waves of VCO1 to control frequency of VCO2 and vice versa). It's also a great way to automate your patch. Simple trick like this can produce interesting harmonic effects.

Come Complex oscillators have built-in wavefolders (stands for the 'timbre knob'), but more about it muuuuuuch Later.

What's the difference between FM (frequency modulation and 1V/OCT inputs?

FM is linear. Quoting Modwiggler forum user: "Both are frequency modulation (FM). But on modular gear usually this means specifically linear FM. The 1V/octave input is scaled for an exponential response, but there are times when it is useful to frequency modulate a VCO or several with a linear voltage. Great for timbral effects."

What is CEM3340 (brief history and significance)?

CEM 3340 Circuit Block and Connection Diagram

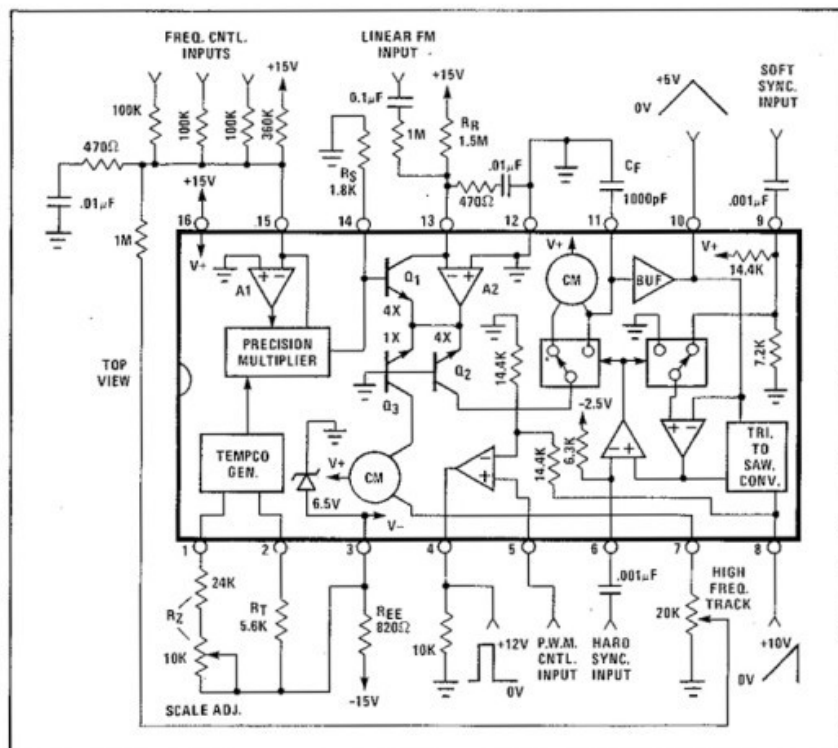

Features

- Large Sweep Range: 50,000:1 min.
- Fully Temperature Compensated; No Q81 Resistor Required
- Four Output Waveforms Available; No waveform trimming required.
- Summing Node Inputs for Frequency Control
- High Exponential Scale Accuracy
- Low Temperature Drift
- Voltage Controlled Pulse Width
- Hard and Soft Sync Inputs
- Linear FM
- Buffered, Short Circuit Protected Outputs
- ±15 Volt Supplies

The cool thing about this chip, is that it has everything built-in, which means the designer doesn't need to add much of additional circuitry. From Electric Druid:

"It provides Ramp, Pulse/Square, and Triangle outputs, has inputs for oscillator sync, is temperature compensated and stable, and provides excellent 1V/Oct tracking. In short, it's everything you need from an analog oscillator, on a chip. There hasn't been a better design than the 3340.

The 3340 is the oscillator chip found in many of the famous polysynths of the analog era; the Sequential Prophet 5 and T8, the Oberheim OB-Xa and OB-8, the Roland Jupiter 6 and MKS-80, and even the MemoryMoog. It also turns up in rarer synths like the Crumar Spirit and the Synton Syrinx."

One of the most challenging tasks when designing analogue VCO is making sure that it has temperature compensation -as it stays on, the voltage slightly increases and warms up the silicon of the semiconductors and consequently, the frequency becomes unstable. This is a problem when using discrete components (transistors).²

Gladly we don't need to worry about that with CEM3340:

"Starting numerically at Pins 1 and 2, this is the temperature compensation circuit. This works by generating a temperature-dependent voltage which is then multiplied on-chip by the incoming CV. Since the VCO and the temperature-compensation circuit are all on the same die, they're all the same temperature, and this gives a highly accurate result. There are still some minor errors from the multiplication process (hey, this is analog, after all) but the datasheet gives details of how to trim those out too if you can be bothered."

What about sync inputs?

Ok, so we know, the magic Integrated Circuit (btw, it's been reissued now under the name AS3340) does all of the work for us, more or less. But what about sync inputs? Syncing oscillators means "resetting their waveshapes to the beginning when they receive a signal from another oscillator. If there is not a precise octave relationship between the two oscillators, the result is a modified waveform that has been reset prematurely, following the frequency of the second oscillator" (source: Learning modular)

² There are many ways of temperature compensation: gluing transistors together so they have the same temperature, using special tempco resistors (fancy temperature-controlled high-mega-ohm resistors). Check out Moritz Klein amazing video tutorials for more in-depth info.

HARD SYNC (with triangle waves)

This is probably the most common type of sync. Every time a sync input signal breaks the threshold, the waveform on the sync'd oscillator resets to the beginning. If the oscillators are different frequencies, you get some interesting overtones, and the root frequency sounds the same.

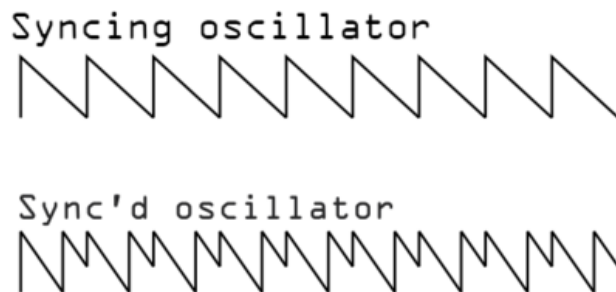

SOFT SYNC

The most common type of soft sync is **phase-reverse soft sync**, which resets the oscillator position when a sync signal breaks the threshold but also reverses the direction of the waveform.

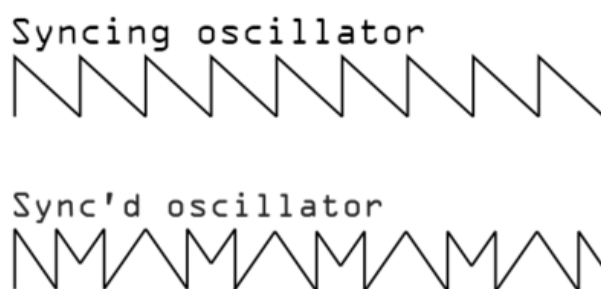

OK, so how does the circuit work?

The Electric Druid article explains it all in depth + definitely check out the datasheet (look in sources section and attached schematic).

The most important pins are:

→ **Pins 1 and 2** - this is the temperature compensation circuit. Easy-peasy. We don't need to worry about any additional circuitry.

3 (source: noise engineering)

→ Pin 11 - VCO's timing capacitor. We want to use good quality capacitor⁴ for this (like film or Mica)⁵. I used 10nf (see schematic).

I also wanted the second oscillator to have wider range than the first one (I also wanted to use pulse out as a trigger output in the lower range of frequencies) so I connected one leg of the RV4 to negative voltage source (-12V).

→ Pin 15 - current input. It's our CV input. This means this pin is a virtual ground inside the chip and you can just add multiple external currents (CVs) to it.

The pin J5 and J12 of the module is connected to the pin 15 via 100k resistors. You can add another CV, or you could just add some offset current (add or subtract a voltage from a signal passing through).⁶

OK, now, time for the most important bit of information. THE CORE OF THE OSCILLATOR.⁷

We spoke previously about the inner workings of oscillators. This will be useful to understand the core of CEM3340.

All of the VCOs have a CORE waveform, from that waveform, other waveforms are derived (waveform, waveform, waveform). So no, we don't build separate oscillators (triangle, sine, square, etc..). We are WAVESHAPING the main oscillator. This can be done by either starting from saw or triangle (apparently triangle core is more stable, but what do I know). CEM3340 is using triangle as a core, which is cool, because Buchla did that in his designs (Moog was starting from saw-cores using transistors, and yes I'm slightly biased towards Buchla).

SO LET'S GET TO THE CORE OF THIS (hehehehe, pan intended)⁸

4 Electronic components have a tolerance range, so if you want to have super precise frequency of the oscillator, you need capacitors which behave stable under higher temperatures.

5 Look the "electronic components guide" attached.

6 Two pots (freq) could act as offsets if the whippers of pots (middle legs) were directly connected to the CV jack inputs. In the current circuit, they set the frequency range.

7 Actually we don't need to worry about this, since CEM3340 has it all built-in. Let's do it anyways.

8 I HIGHLY recommend watching videos of Aaron Lanterman which are included in the source list.

So we are flipping the incoming current source (which then is converted to voltage) between + and - via an INTEGRATOR.⁹ Then we compare the fluctuating signal to the square wave (rather than static threshold like in our usual oscillator). So that's cool as we are getting two waveforms out of this! What's happening is that we are constantly COMPARING (via comparator circuit) between upper and lower threshold.

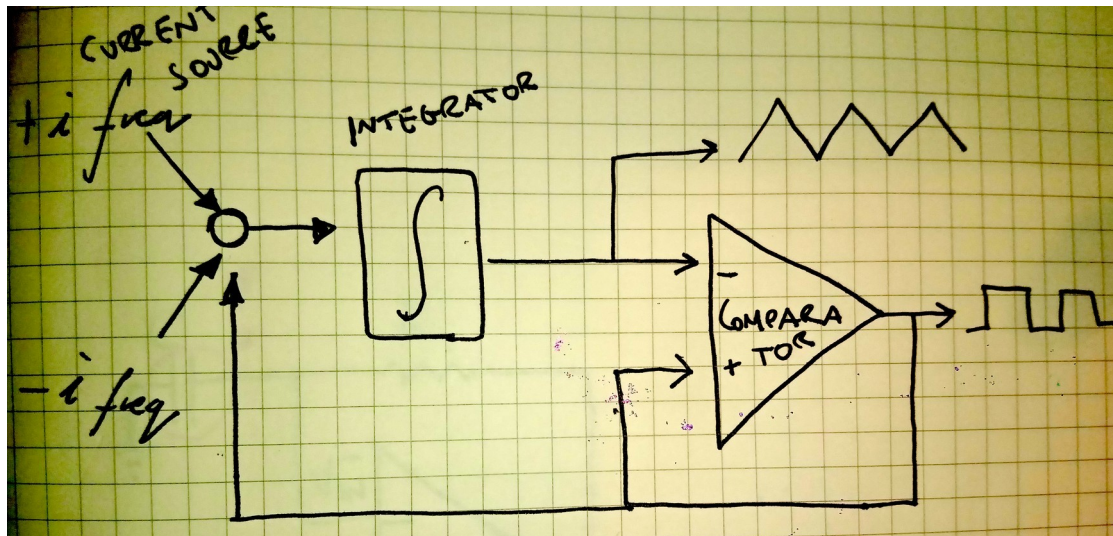

But how Buchla did this and where's the capacitor?????

Buchla's original VCO core looks like this:

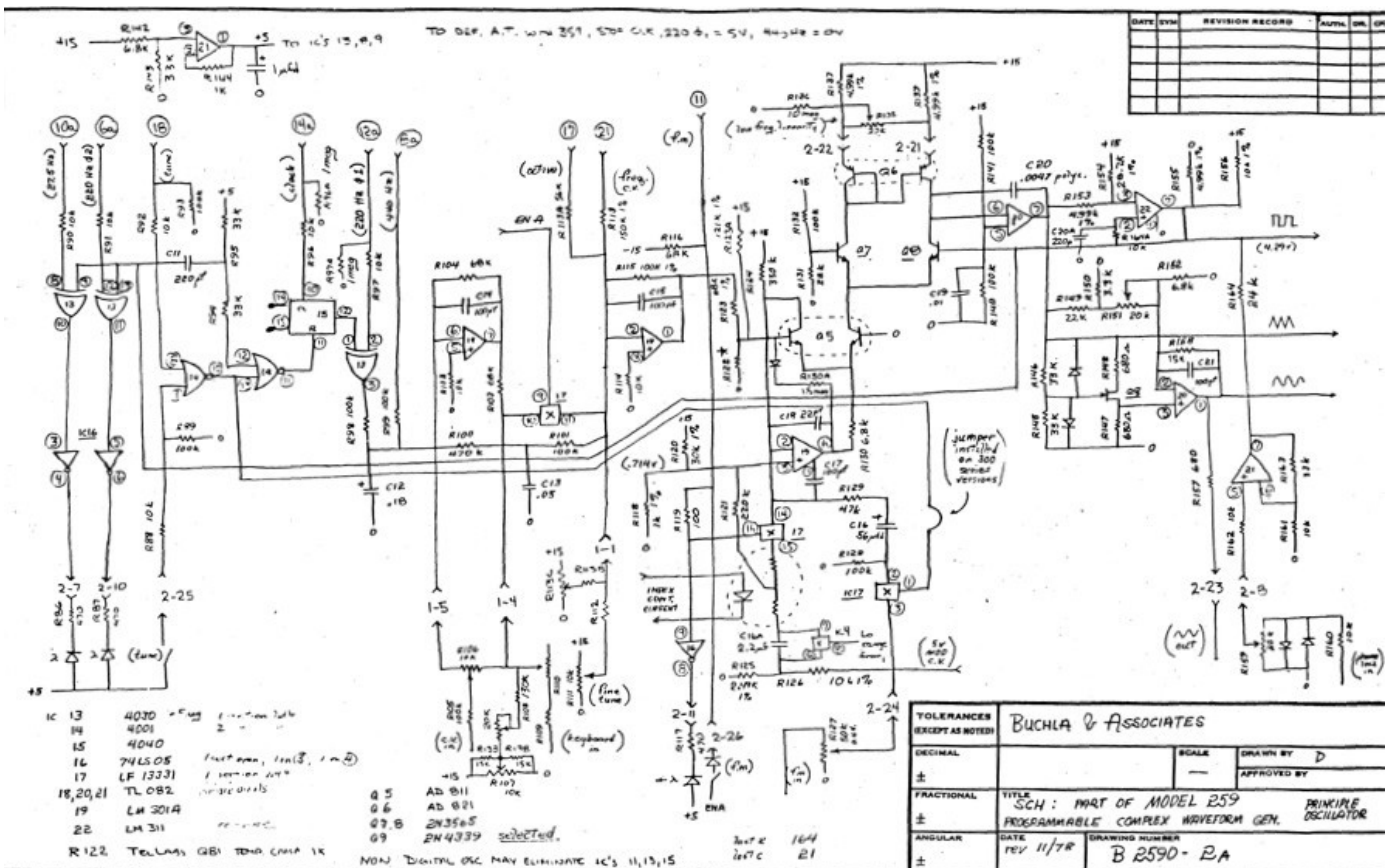

Now.. try to find the triangle core..

In a simplified form, it should look like this (which is the inside of CEM3340):

"The triangle core uses a charging current and an integrating capacitor to produce a linear change in voltage until a reset voltage is reached. However, when this occurs, instead of discharging the capacitor abruptly, the triangle core reverses the charging current. The voltage changes linearly, in the opposite direction, until the reset voltage is reached in the opposite direction, and then the charging current reverses again. Triangle cores have the advantage that they do not require high frequency compensation (as saw-cores usually get out of tune on higher frequencies, which requires additional scaling circuitry).

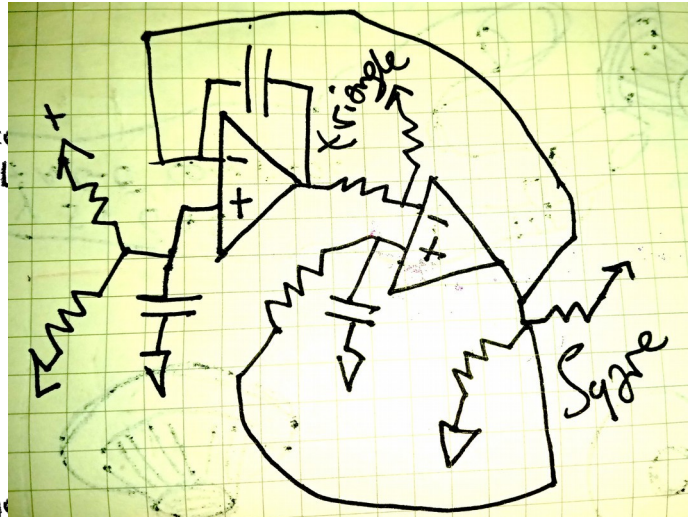

The most commonly used VCO design to employ a triangle core was the Curtis 3340. Several modular synth VCO designs have used triangle cores. The ARR500 employed an unusual VCO design which used both sawtooth and triangle cores, tied to a common reset mechanism to keep them in phase." (electronicmusic.fandom.com)

sources:

<https://learningmodular.com/glossary/>

<https://www.electronics-tutorials.ws/opamp/op-amp-multivibrator.html>

<https://www.electrical4u.com/voltage-controlled-oscillator/>

<https://electricdruid.net/cem3340-vco-voltage-controlled-oscillator-designs/>

<https://hackaday.io/project/160538-cem3340-module>

<https://secretlifeofsynthesizers.com/the-vco/>

<https://modwiggler.com/forum/viewtopic.php?t=169687>

https://monoskop.org/File:Oram_Daphne_An_Individual_Note_of_Music_Sound_and_Electronics.pdf

<https://hackaday.com/2015/09/11/Logic-noise-playing-in-tune-with-an-exponential-vco/>

<https://www.perfectcircuit.com/signal/learning-synthesis-oscillators>

https://www.youtube.com/watch?v=vZriAoE9MA4&ab_channel=Lantertronics-AaronLanterman

https://www.youtube.com/watch?v=vZriAoE9MA4&ab_channel=Lantertronics-AaronLanterman

https://www.youtube.com/watch?v=qF4G4QfC9dM&ab_channel=Lantertronics-AaronLanterman
<http://retrosynthads.blogspot.com/2011/07/curtis-electromusic-specialties-what.html>
<https://output.com/blog/synth-voice-eurorack>
https://www.birthofasynth.com/Thomas_Henry/Pages/VCO-1.html
<http://creativosaldebaran.blogspot.com/2019/01/1st-eso-art-color-light-vs-color-pigment.html>
<https://modularsynthesis.com/roman/buchla259/Buchla%20259%20Description%20-%20Buchla%20Synthesizer%20User%20Guide%2011-16-1981.pdf>
<https://modularsynthesis.com/roman/buchla259/259cwg.htm>
https://www.reddit.com/r/synthesizers/comments/f2iqzw/is_there_more_to_a_vco_than_the_voice_chip/
<https://www.synthanatomy.com/2021/02/st-modular-oberhausen-diy-complex-oscillator-with-lots-of-shaping-options.html>
https://www.reddit.com/r/modular/comments/btq3ub/some_disturbing_questions_about_complex/
<https://modwiggler.com/forum/viewtopic.php?t=56950>
<https://electricdruid.net/wp-content/uploads/2020/02/CEM33403345-VCO.pdf>
https://www.youtube.com/watch?v=dd1dws6pSNo&ab_channel=MoritzKlein
<https://noiseengineering.us/blogs/loquelic-literitas-the-blog/everything-but-the-kitchen-sync-except-this-post-is-actually-about-sync>
<http://manuals.fdiskc.com/flat/Buchla%20200%20Series%20Schematics.pdf>
https://electronicmusic.fandom.com/wiki/Triangle_core